

EMI/EMC FILTER

IH SERIES



Features

- Ideally suited for products that must conform to part 15, FCC regulations
- Metal cased miniature type with high performance
- Meet over voltage category II of IEC 60664 and comply with IEC 60950
- Uses IEC connector that meets the safety standards from certification bodies
- Snap in type for quick mounting
- Both soldering lug type and faston tab type are available

Applications

- Digital equipments
- Personal computers and peripherals
- Measuring instruments
- For use in miniature equipments
- For monitors display units

Specifications

MODEL	Rated Voltage (AC, DC)	Rated Current	Leakage Current (250V AC)	Operating Temperature
IH-(N)01**-*	250V	1A	-	-25°C to +85°C Including temperature rise
IH-(N)02**-*	250V	2A	-	
IH-(N/L)03**-*	250V	3A	-	
IH-(N)06**-*	250V	6A	-	
IH-N08**-*	250V	8A	-	
IH-(N)10**-*	250V	10A	-	
IH-(N)15**-*	250V	15A	-	
IH-(N)**0-*	-	-	0.01mA max.	
IH-(N)**C-*	-	-	0.075mA max.	
IH-(N)**D-*	-	-	0.10mA max.	
IH-(N)**E-*	-	-	0.20mA max.	
IH-(N)**1-*	-	-	0.25mA max.	
IH-(N)**2-*	-	-	0.35mA max.	
IH-(N)**3-*	-	-	0.50mA max.	

Note

Test Voltage : 1500V AC one minute, line to earth
 Insulation Resistance : 300 Mohm min. at 500V DC
 Voltage Drop : 1V max. at rated current
 Weight : 45g
 Inlet : Compatible with IEC-60320
 15A(UL, CSA only)

Model Number Construction

I	H	03	4	2	S
Input Connector I : IEC Connector	Special Design H : Snap-in with Lock spring	Current Rating : AC rms 01,N01 : 1amp 02,N02 : 2amp 03,N03,L03 : 3amp 06,N06 : 6amp N08 : 8amp 10,N1 : 10amp 15,N15 : 15amp ("L","N" high performance)	Line-Line Cap.Value 2 : 0.022 μF 4 : 0.047 μF A : 0.1 μF B : 0.15 μF	Line-Gnd Cap.Value 1 : 1500 pF 2 : 2200 pF 3 : 3300 pF C : 330 pF D : 470 pF E : 1000 pF 0 : None	Output Terminal H : Faston Tab #250

Shapes and Dimensions

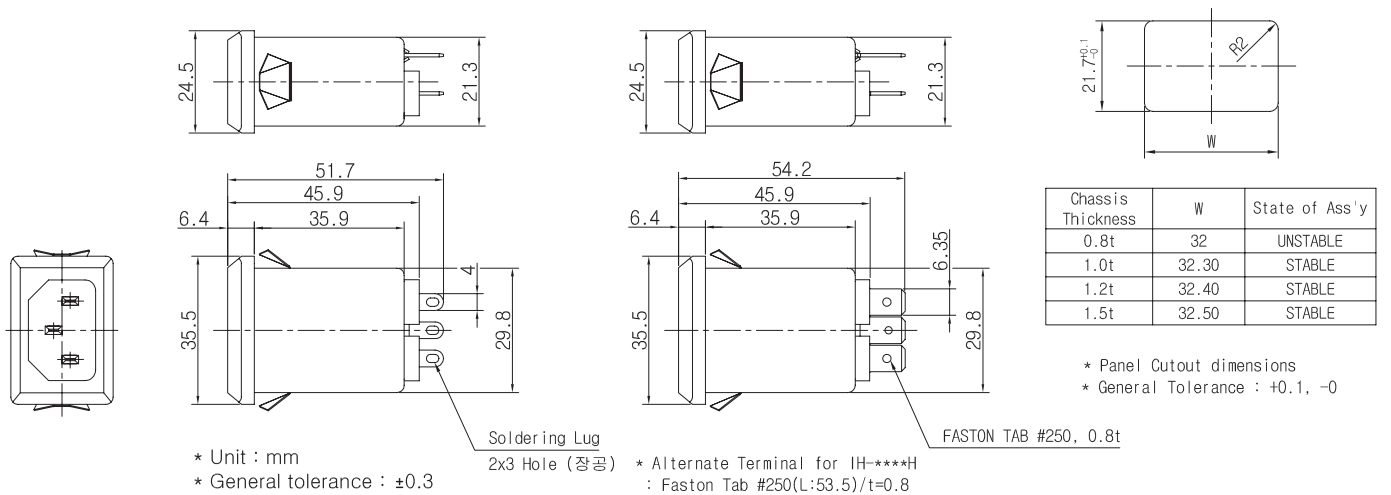

Attenuation Characteristics

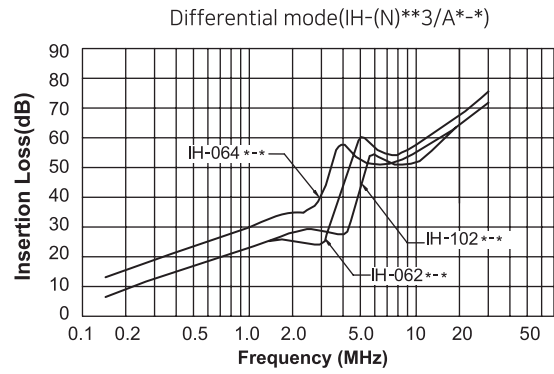
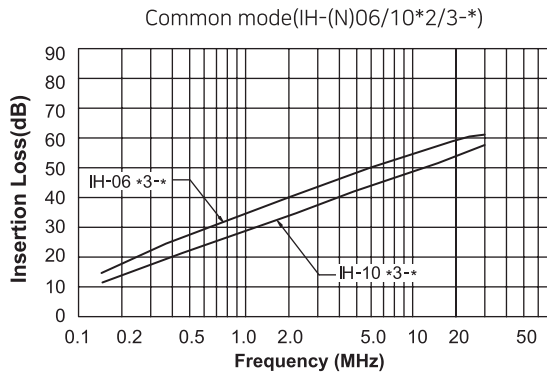
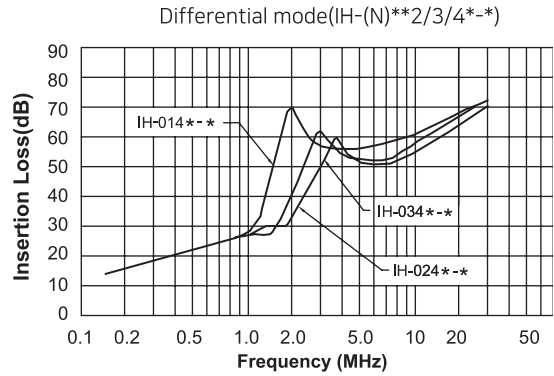
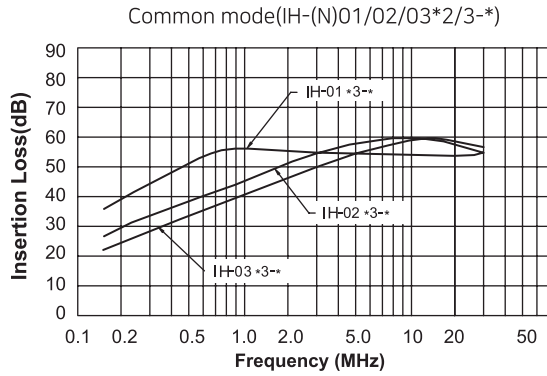

Circuit Diagram

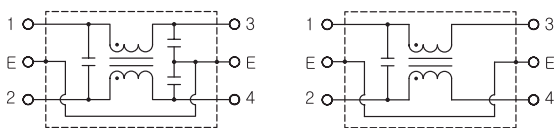

IH-***-* type

IH-***0-* type

Measurement Configuration

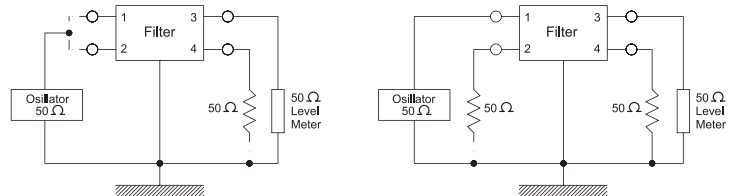

Common mode

Differential mode